

RS Gun Cutter Assemblies

332574G

EN

*For use with RS Guns to chop fiberglass to dispense into a mixed material stream.
For professional use only.*

Models

24E512, Cutter, External Mix Gun, Series D

24P681, Cutter, Internal Mix Gun, Series D

100 psi (0.7 MPa, 7.0 bar) Maximum Working Pressure



Important Safety Instructions

Read all warnings and instructions in this manual and in the RS Gun and Cutter Operation-Repair manual before using the equipment. Save all instructions.

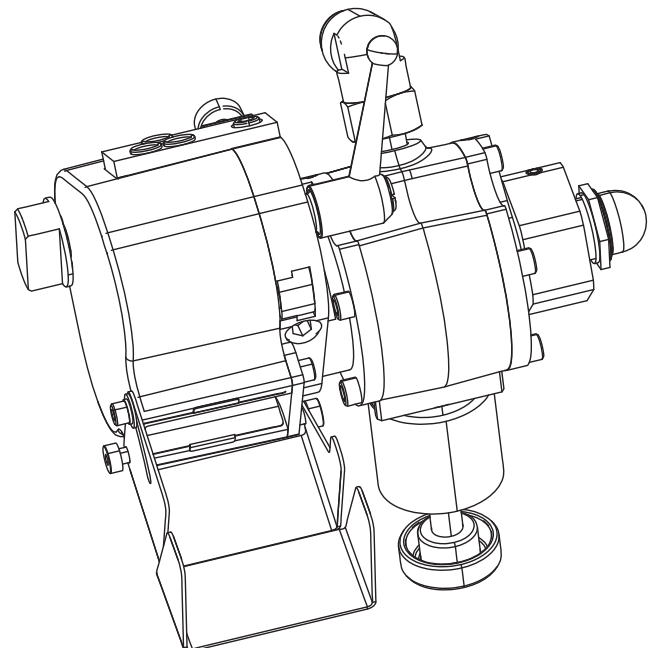

Contents

Related Manuals	3	Repair	21
Agency Approvals	3	Air Motor Removal	21
Warnings	4	Air Motor Disassembly	21
Important Two-Component Information	6	Air Motor Rebuild	23
Material Self-Ignition	6	Air Motor Replacement	25
Keep Components A and B Separate	6	Parts	26
Changing Materials	6	Cutter Assembly, 24E512 and 24P681	26
Important Methyl Ethyl Ketone Peroxide (MEKP) Information	7	Air Motor, 24E511	28
Component Identification	9	Kits and Accessories	30
Setup	10	Air Motor Rebuild Kit, 25E490	30
Grounding	10	Anti-Rotation Rebuild Kit, 25E491	30
Connect to the RS Gun	10	Muffler Kit, 25E492	30
Adjust the Anvil to Blade Tension	11	Stop Button Cover Kit, 25E493	30
Operation	12	Muffler Packing Kit, 25E494	30
Pressure Relief Procedure	12	Air Motor Rebuild Tools Kit, 25E508	30
Modes of Operation	12	Chopper Air Shutoff, 24F706	30
Premature Blade or Anvil Wear	12	External Mix Gel Gun to Chop Gun Conversion	30
Anvil and Blade Replacement	12	Internal Mix Gel Gun to Chop Gun Conversion	30
Adjust Cutter Speed	13	Oil for Air Motor	31
Adjust Anvil to Cutter Head Tension	13	Cutter Chop Chutes	31
Adjust Anvil to Idler Tension	14	Cover and Chutes	31
Maintenance	15	Blade Cartridges	31
Air Motor Oiling	15	Cutter Chute Liner, 16P833	31
Replace Anvil	16	Tools	32
Replace Blades	16	Carbide Resin Seat, 24M833	32
Replace Chopper Chute Liner	17	Two Hole Feeder Bar, 24M569	32
Replace the Muffler Filters	18	Cutter Head Kits	32
Troubleshooting	19	Technical Specifications	33
		Graco Standard Warranty	34

Related Manuals

The following is a list of component manuals written in English. These manuals and any translated versions available can be found at www.graco.com.

Part	Description
3A0232	RS Gun and Cutter, Operation-Repair

Agency Approvals



II 2 G Ex h T6 Gb







Warnings

The following warnings are for the setup, use, grounding, maintenance, and repair of this equipment. The exclamation point symbol alerts you to a general warning and the hazard symbols refer to procedure-specific risks. When these symbols appear in the body of this manual or on warning labels, refer back to these Warnings. Product-specific hazard symbols and warnings not covered in this section may appear throughout the body of this manual where applicable.

 <h2 style="margin: 0;">WARNING</h2>	
   	<p>FIRE AND EXPLOSION HAZARD</p> <p>Flammable fumes, such as solvent and paint fumes, in work area can ignite or explode. Paint or solvent flowing through the equipment can cause static sparking. To help prevent fire and explosion:</p> <ul style="list-style-type: none"> • Use equipment only in well-ventilated area. • Eliminate all ignition sources; such as pilot lights, cigarettes, portable electric lamps, and plastic drop cloths (potential static sparking). • Ground all equipment in the work area. See Grounding instructions. • Never spray or flush solvent at high pressure. • Keep work area free of debris, including solvent, rags and gasoline. • Do not plug or unplug power cords, or turn power or light switches on or off when flammable fumes are present. • Use only grounded hoses. • Hold gun firmly to side of grounded pail when triggering into pail. Do not use pail liners unless they are anti-static or conductive. • Stop operation immediately if static sparking occurs or you feel a shock. Do not use equipment until you identify and correct the problem. • Keep a working fire extinguisher in the work area.
    	<p>SKIN INJECTION HAZARD</p> <p>High-pressure fluid from dispensing device, hose leaks, or ruptured components will pierce skin. This may look like just a cut, but it is a serious injury that can result in amputation. Get immediate surgical treatment.</p> <ul style="list-style-type: none"> • Engage trigger lock when not dispensing. • Do not point dispensing device at anyone or at any part of the body. • Do not put your hand over the fluid outlet. • Do not stop or deflect leaks with your hand, body, glove, or rag. • Follow the Pressure Relief Procedure when you stop dispensing and before cleaning, checking, or servicing equipment. • Tighten all fluid connections before operating the equipment. • Check hoses and couplings daily. Replace worn or damaged parts immediately.



WARNING

 	<p>MOVING PARTS HAZARD</p> <p>Moving parts can pinch, cut or amputate fingers and other body parts.</p> <ul style="list-style-type: none"> • Keep clear of moving parts. • Do not operate equipment with protective guards or covers removed. • Pressurized equipment can start without warning. Before checking, moving, or servicing equipment, follow the Pressure Relief Procedure and disconnect all power sources.
	<p>TOXIC FLUID OR FUMES HAZARD</p> <p>Toxic fluids or fumes can cause serious injury or death if splashed in the eyes or on skin, inhaled, or swallowed.</p> <ul style="list-style-type: none"> • Read Safety Data Sheets (SDSs) to know the specific hazards of the fluids you are using. • Store hazardous fluid in approved containers, and dispose of it according to applicable guidelines.
 	<p>EQUIPMENT MISUSE HAZARD</p> <p>Misuse can cause death or serious injury.</p> <ul style="list-style-type: none"> • Do not operate the unit when fatigued or under the influence of drugs or alcohol. • Do not exceed the maximum working pressure or temperature rating of the lowest rated system component. See Technical Specifications in all equipment manuals. • Use fluids and solvents that are compatible with equipment wetted parts. See Technical Specifications in all equipment manuals. Read fluid and solvent manufacturer's warnings. For complete information about your material, request Safety Data Sheets (SDSs) from distributor or retailer. • Do not leave the work area while equipment is energized or under pressure. • Turn off all equipment and follow the Pressure Relief Procedure when equipment is not in use. • Check equipment daily. Repair or replace worn or damaged parts immediately with genuine manufacturer's replacement parts only. • Do not alter or modify equipment. Alterations or modifications may void agency approvals and create safety hazards. • Make sure all equipment is rated and approved for the environment in which you are using it. • Use equipment only for its intended purpose. Call your distributor for information. • Route hoses and cables away from traffic areas, sharp edges, moving parts, and hot surfaces. • Do not kink or over bend hoses or use hoses to pull equipment. • Keep children and animals away from work area. • Comply with all applicable safety regulations.
	<p>PERSONAL PROTECTIVE EQUIPMENT</p> <p>Wear appropriate protective equipment when in the work area to help prevent serious injury, including eye injury, hearing loss, inhalation of toxic fumes, and burns. Protective equipment includes but is not limited to:</p> <ul style="list-style-type: none"> • Protective eyewear, and hearing protection. • Respirators, protective clothing, and gloves as recommended by the fluid and solvent manufacturer.

Important Two-Component Information

Material Self-Ignition



Some materials may become self-igniting if applied too thick. Read material manufacturer's warnings and Safety Data Sheets (SDSs).

Keep Components A and B Separate



Cross-contamination can result in cured material in fluid lines which could cause serious injury or damage equipment. To prevent cross-contamination:

- **Never** interchange component A and component B wetted parts.
- Never use solvent on one side if it has been contaminated from the other side.

Changing Materials

NOTICE

Changing the material types used in your equipment requires special attention to avoid equipment damage and downtime.

- When changing materials, flush the equipment multiple times to ensure it is thoroughly clean.
- Always clean the fluid inlet strainers after flushing.
- Check with your material manufacturer for chemical compatibility.
- When changing between epoxies and urethanes or polyureas, disassemble and clean all fluid components and change hoses. Epoxies often have amines on the B (hardener) side. Polyureas often have amines on the B (resin) side.

Important Methyl Ethyl Ketone Peroxide (MEKP) Information

MEKP is among the more hazardous materials used in the plastics industry. MEKP contains highly reactive (unstable) chemicals that produce the curing reaction of polyester resins and gel-coats in a laminating operation. The highly reactive property of MEKP also produces hazards that require great care and caution in the handling, processing, storage, transportation and disposal of MEKP.



MEKP is flammable and potentially explosive when reacting to contamination by other materials or when exposed to heat or heat build-up from contamination reactions. A contamination reaction can cause MEKP to reach its Self-Accelerating Decomposition Temperature (SADT). Reaction may start slowly, taking from seconds to days, gradually building up heat. This can produce a violent explosion. To help prevent fire and explosion:

- Read and understand the MEKP manufacturer's warnings and Safety Data Sheets (SDSs) to know specific hazards and precautions related to MEKP.
- Prevent contamination of MEKP with other materials (even small amounts), including but not limited to diluents, polyester overspray, sanding dust, polymerization accelerators and promoters, and non-stainless metals. Keep work area clean and free of waste.
- Never return MEKP to the original container.
- Remove spills promptly so no residues remain. Spillage can heat up to the point of self-ignition.
- Keep MEKP away from heat, sparks and open flames. Do not smoke in the work area.
- Never dilute MEKP with acetone or any solvent. This can produce an extremely shock-sensitive compound that can explode.
- Use only genuine manufacturer's parts in the catalyst system (hoses, fittings, etc.). A reaction may result between substituted parts and MEKP.
- Store MEKP in the original containers in a cool, dry and well-ventilated area away from direct sunlight and away from other chemicals in accordance with MEKP manufacturer's recommendations.
- Do not store MEKP for an extended period of time. Extended storage will increase the potential for explosive decomposition. Rotate stock using the oldest material first. Refer to NFPA 432 and MEKP manufacturer's recommendations.
- To prevent contact with MEKP, wear appropriate personal protective equipment, including chemically impermeable gloves, boots, aprons and goggles.

Polyester Resins and Gel-Coats

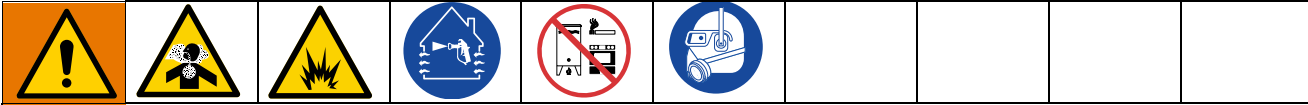

Spraying materials containing polyester resin and gel-coats creates potentially harmful mist, vapors and atomized particulates.

- Prevent inhalation by providing sufficient ventilation and using respirators in the work area.
- Read and understand the material manufacturer's warnings and Safety Data Sheets (SDSs) to know specific hazards and precautions related to polyester resins and gel-coats.
- If cleaning solvents are used in the spraying and lamination operation, read and understand solvent manufacturer's warnings and SDSs to know specific hazards and precautions related to the solvent. (Graco recommends that clean-up solvents be nonflammable.)
- To prevent contact with polyester resins and gel-coats, wear appropriate personal protective equipment, including chemically impermeable gloves, boots, aprons and goggles.

NOTE: Graco recommends that you consult OSHA 29 CFR Sections 1910.94, 1910.106, 1910.107 and NFPA No. 33, and NFPA No. 91 for further guidance.

Component Identification

Cutter, 24E512, External Mix Gun, Series D
Cutter, 24P681, Internal Mix Gun, Series D

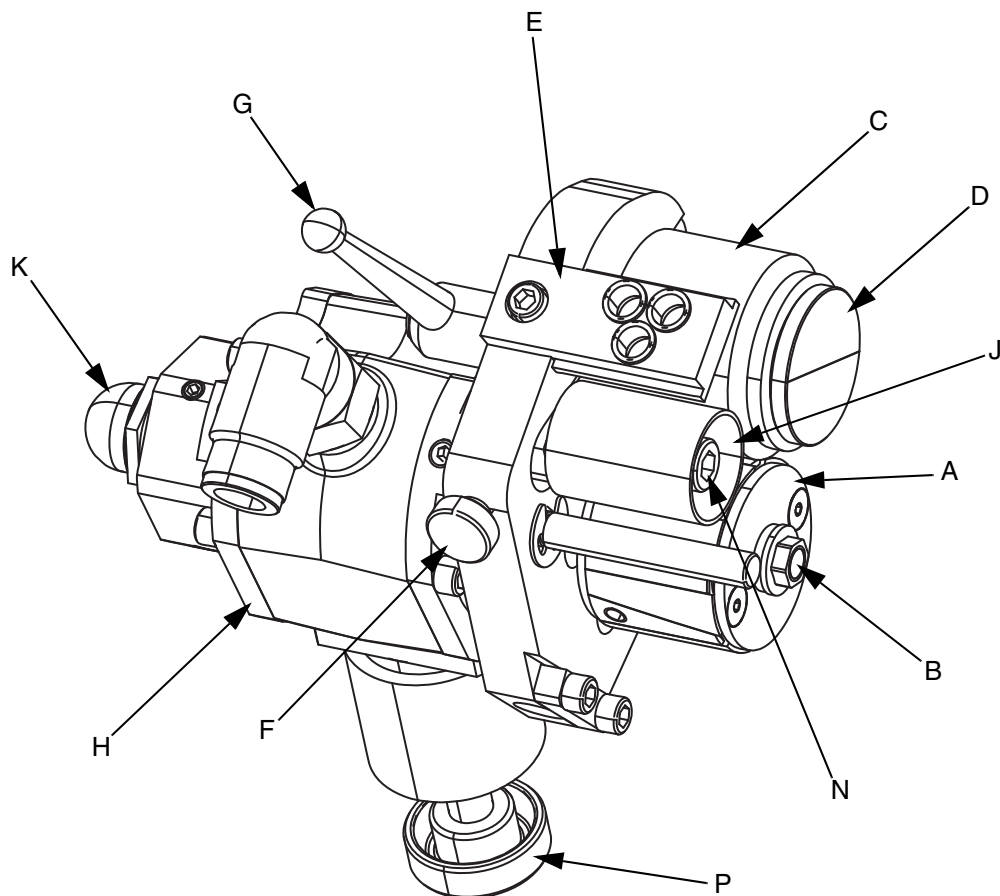

FIG. 1: Component Identification

Key:

A	Cutter Head	H	Air Motor
B	Cutter Head Clamp Screw	J	Idler Wheel
C	Anvil	K	Motor Lock button
D	Anvil Cap	L	Cover (not shown)
E	Glass Feed	M	Chute (not shown)
F	Anvil to Blade Tension Adjustment Knob	N	Idler Lockdown Screw
G	Anvil to Blade Tension Lockdown	P	Speed Control Knob

Setup

Letters in parenthesis are used in this section for reference to callouts in **Component Identification** on page 9. Numbers in parenthesis are used in this section for reference to callouts in **Cutter Assembly, 24E512 and 24P681** on page 26.

Grounding



The equipment must be grounded to reduce the risk of static sparking. Static sparking can cause fumes to ignite or explode. Grounding provides an escape wire for the electric current.

The cutter assembly is grounded through the RS Gun. Refer to the RS Gun and Cutter Operation-Repair manual for additional grounding information related to the RS Gun. See **Related Manuals** on page 3.

Connect to the RS Gun

1. Engage the trigger lock on the RS Gun.

NOTE: If you are connecting this cutter assembly to a Series F or earlier RS gun, proceed to step 2. If you have a Series G or later RS gun, start with step 5 to connect the cutter assembly. The parts required for steps 2 to 4 are included with the cutter assembly.

2. Use a crescent wrench to remove air tube fittings A and B and the 1/4 in. air tube from the RS gun, as shown in **Figure 2**.

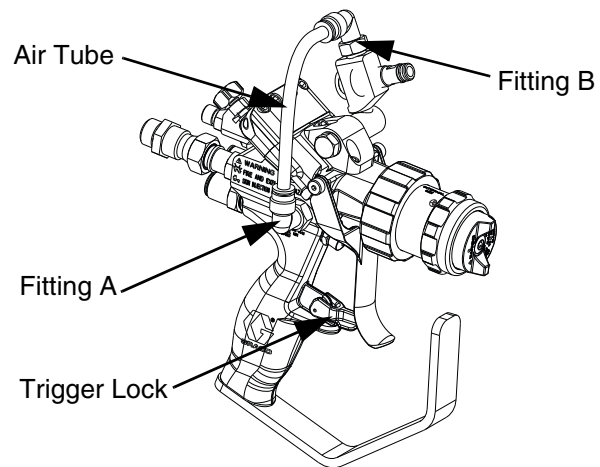

FIG. 2

3. Refer to **Figure 3**. Use a 3/16 in. hex wrench to install the plug (159) included with the cutter assembly where Fitting B was removed.

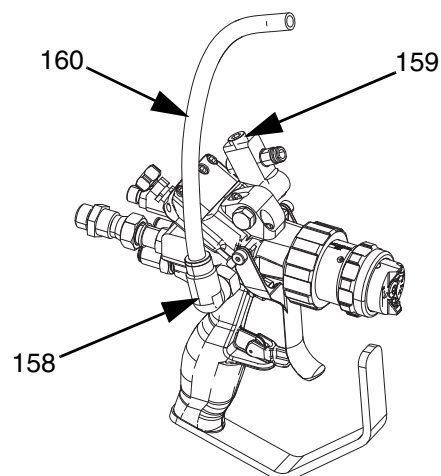

FIG. 3

- Use a crescent wrench to install the new elbow fitting (158) and the 3/8 in. air tube (160) where Fitting A was removed.
- If necessary, use a crescent wrench to adjust the pivot so that it is parallel to the gun front with the open end pointing to the front of the gun. See **Figure 4**.

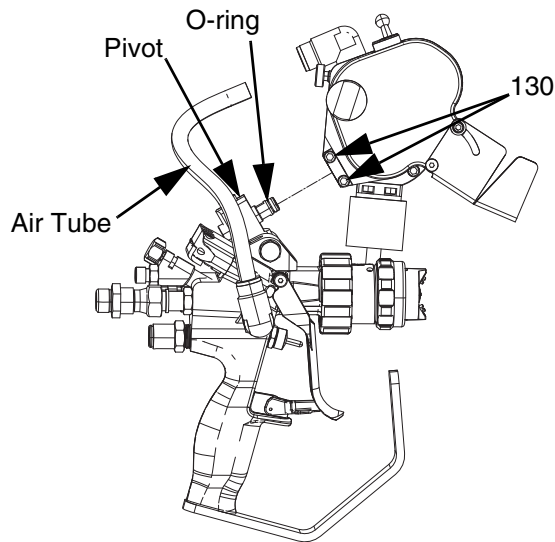

FIG. 4

- Back out the screws (130). See **Figure 4**.
- Install the cutter onto the pivot so the glass feed holes are on the top.

NOTE: Ensure proper engagement of the o-ring into the cutter assembly. Verify that there is no excess air leakage because it will greatly reduce the performance of the air motor. See **Figure 4**.

- Tighten the screws (130) to lock the cutter in place.
- Connect the air tube from the gun to the air motor on the cutter.
- Adjust the cutter dispensing angle and chute angle as desired.
- Insert the glass strands into the feed.

Adjust the Anvil to Blade Tension

- Release the anvil to blade tension lockdown (G) by pushing it towards the front of the gun.
- Adjust the tension knob (F) as desired.
- Tighten the lockdown (G).



- Remove the release knob (128) and cover (127).
- Release the idler lockdown screw (N).
- Adjust the idler wheel (J) until it touches the anvil (C).
- Tighten the idler lockdown screw (N).
- Replace the cover (127) and release knob (128).
- Perform a test spray to verify proper cutting of the glass strands.
- Adjust tension as necessary.

Operation



To prevent personal injury from pinching or cutting and skin injection, engage the trigger lock on the RS gun when you stop spraying and before cleaning, checking, or servicing the equipment.

Letters in parenthesis are used in this section for reference to callouts in **Component Identification** on page 9. Numbers in parenthesis are used in this section for reference to the callouts in **Cutter Assembly, 24E512 and 24P681** on page 26.

Pressure Relief Procedure

 Follow the Pressure Relief Procedure whenever you see this symbol.



To prevent personal injury from pinching or cutting and skin injection, follow the Pressure Relief Procedure in the RS Gun and Cutter Operation-Repair manual when you stop spraying and before cleaning, checking, or servicing the equipment. See **Related Manuals** on page 3.

Modes of Operation

RS guns with a cutter installed have two modes of operation. When the trigger is pulled halfway, material sprays but the cutter is not activated. When the trigger is pulled all the way, the air motor in the cutter is started and glass begins dispensing.

Premature Blade or Anvil Wear

NOTICE

More tension between the anvil and blades leads to the anvil and blades wearing out faster. To prevent premature wear and to maximize anvil and blade life, use the minimum tension required to cut the glass and make small increases in tension when strands are not cut correctly.

The most common causes of premature anvil or blade wear are excessive tension between the anvil and blades, excessive cutter speed, and excessive tension between the idler wheel and anvil. See page 13 for the **Adjust Anvil to Cutter Head Tension** procedure.

To reduce the cutter speed while keeping the same glass output, perform the following procedure:

1. Do a bag check to establish a baseline for the current cutter output.
 - a. Weigh a bag.
 - b. Dispense glass into the bag for 15 or 30 seconds depending on the output.
 - c. Weigh the bag to determine glass output. This is your fiberglass output baseline.
2. Add another strand of roving to the cutter inlet.
3. Engage the trigger lock on the RS gun.
4. With the trigger lock engaged, rotate the speed control knob (P) counter-clockwise to decrease speed. If necessary, rotate clockwise to increase speed.
5. Do another bag check to determine the new glass output.
 - a. Weigh a bag.
 - b. Dispense glass into the bag for the same amount of time as in step 1b.
 - c. Weigh the bag to determine glass output.
6. If the weight does not match the baseline bag weight, adjust the cutter speed then do another bag check. Repeat until the new bag weight matches the baseline bag weight.

Anvil and Blade Replacement

See **Replace Anvil** and **Replace Blades** procedures on page 16.

Adjust Cutter Speed

When dispensing a material and glass mixture, the speed at which the cutter spins can be adjusted to ensure the correct ratio of glass to dispensed material.

NOTE: It may be possible to prevent premature anvil and blade wear by slowing the cutter speed and adding an additional strand of roving. See **Premature Blade or Anvil Wear** on page 12.

1. Determine whether more or less glass is needed.
 - a. Place a bag over the cutter chute.
 - b. Place a bag over the gun fluid outlet. Put the bag close enough to catch the fluid but far enough away to avoid piercing the bag when dispensing to prevent inaccurate dispense measurements.
 - c. Dispense a 15-30 second shot.
 - d. Weigh both bags and calculate the ratio.
 - e. Determine whether more or less glass is needed. Consult the material manufacturer recommendations for ratio requirements.
 - f. If the ratio is satisfactory, no adjustment is needed. Otherwise, continue with the adjustment procedure.
2. Engage the trigger lock on the RS gun.
3. With the trigger lock engaged, rotate the speed control knob (P) on the air motor counter-clockwise to decrease speed, clockwise to increase speed.
4. Go to step 1 to test the ratio and repeat adjustment as necessary.
5. Tighten the speed control knob (P) to avoid speed changes during operation.

Adjust Anvil to Cutter Head Tension

NOTICE

More tension leads to the anvil and blades wearing out faster. To prevent premature wear and to maximize anvil and blade life, use the minimum tension required to cut the glass and make small increases in tension when strands are not cut correctly.

To cut the glass strands, the blades are pressed against the anvil. If the strands do not appear to be cutting correctly, adjust the tension as follows.

1. Engage the trigger lock on the gun.
2. Disengage the tension lockdown (G) by pushing it towards the front of the gun.
3. Turn the tension knob (F) on the cutter counter-clockwise to increase tension and clockwise to decrease tension.
4. Engage the tension lockdown by pulling it back (G).

If there is still excessive anvil or blade wear after performing this procedure, see **Premature Blade or Anvil Wear** on page 12.

Adjust Anvil to Idler Tension



Follow these steps to adjust the anvil to idler tension,

1. Follow the **Pressure Relief Procedure** in the RS Gun and Cutter, Operation-Repair manual. .
2. Engage the trigger lock.
3. Remove the release knob (128) and cover (127).



Blades are sharp. Always wear protective gloves to prevent cuts when the cutter cover is removed.

4. Loosen the idler lockdown screw (117) using a 3/16 in. hex key.
5. Slide the idler to the desired position.
6. Tighten the idler lockdown screw (117) to lock the idler in position and replace the release knob (128) and cover (127).

Maintenance

Letters in parenthesis are used in this section for reference to callouts in **Component Identification** on page 9. Numbers in parenthesis are used in this section for reference to **Cutter Assembly, 24E512 and 24P681** on page 26.

Tools Required

The following tools are required to perform regular maintenance on the gun.

- 7/16 in. wrench
- 1/2 in. wrench
- 9/16 in. wrench
- 5/8 in. wrench
- 11/16 in. wrench
- 3/4 in. wrench
- 13/16 in. wrench
- 5/64 in. allen key
- 3/32 in. allen key (supplied)
- 9/64 in. allen key (supplied)
- 3/16 in. allen key (supplied with cutter assembly)
- 1/2 in. deep well socket
- 9/32 in. socket
- 7/32 in. deep well socket
- 5/16 in. nut drive (supplied)

Task	Schedule
Add oil to the air motor, page 15.	3-4 drops per 8 hours of use.
Replace the anvil, page 16.	When surface is badly scored or does not cut.
Replace the blades, page 16.	When glass roving is no longer cut cleanly (verify proper tension first).

Air Motor Oiling



1. Perform the **Pressure Relief Procedure** in the RS Gun and Cutter, Operation-Repair manual. See **Related Manuals** on page 3.
2. Engage the trigger lock on the RS gun.
3. Remove the air tube and add 3-4 drops of air motor oil, Graco part 202659, into the air fitting port.

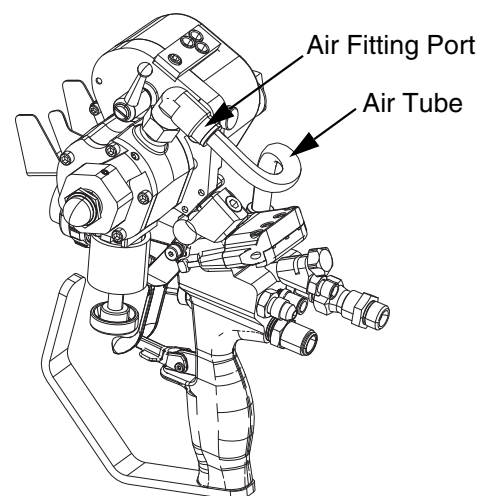

FIG. 5

Replace Anvil



Replace the anvil when the surface is badly scored or the glass is not cutting.

1. Follow the **Pressure Relief Procedure** in the RS Gun and Cutter, Operation-Repair manual. See **Related Manuals** on page 3.
2. Engage the trigger lock on the RS gun.
3. Loosen the release knob (128) and remove the cover (127).



Blades are sharp. Always wear protective gloves to prevent cuts when the cutter cover is removed.

4. Use a hand to prevent the anvil from spinning, then push in and rotate the anvil cap (D) 90 degrees counter-clockwise to remove it.
5. Loosen the anvil to blade tension lockdown lever (G).
6. Use the anvil to blade tension adjustment knob (F) to relieve the tension between the anvil and blades.
7. Remove anvil (C).
8. Install the new anvil onto the sleeve.
9. Install the anvil cap (D).
10. Install the cover (127) and knob (128).

NOTICE

More tension between the anvil and blades leads to the anvil and blades wearing out faster. To prevent premature wear and to maximize anvil and blade life, use the minimum tension required to cut the glass and make small increases in the tension when strands are not cut correctly.

11. Refer to **Adjust Anvil to Cutter Head Tension** on page 13.

Replace Blades



If glass is not getting cut properly, verify the tension is correct before replacing the blades.

1. Follow the **Pressure Relief Procedure** in the RS Gun and Cutter, Operation-Repair manual. See **Related Manuals** on page 3.
2. Engage the trigger lock on the RS gun.
3. Remove the release knob (128) and cover (127).



Blades are sharp. Always wear protective gloves to prevent cuts when the cutter cover is removed.

4. Press and hold the motor lock button (K) to prevent the cutter head (A) from spinning.
5. Loosen the cutter head clamp screw (B) and remove the cutter head clamp (154).

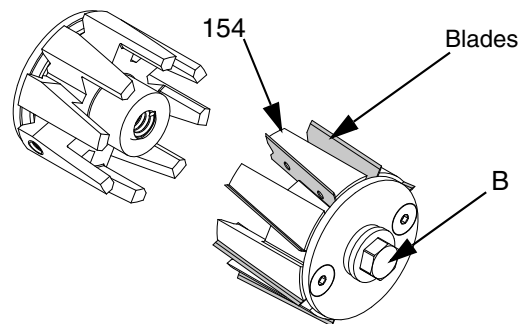

FIG. 6

6. Replace the blades. See **Blade Cartridges** on page 31.

NOTE: Ensure the blades are all seated on the angled face of the cutter head base.

7. Replace the cutter head clamp (154) with blades.
8. Tighten the cutter head clamp screw (B).

- Install the cover (127) and release knob (128).

NOTICE
<p>More tension between the anvil and blades leads to the anvil and blades wearing out faster. To prevent premature wear and to maximize anvil and blade life, use the minimum tension required to cut the glass and make small increases in tension when strands are not cut correctly.</p>

- Refer to **Adjust Anvil to Cutter Head Tension**, page 13.

NOTICE
<p>The cutter head may be higher than the anvil quarter turn lock surface due to incorrect blade installation and may result in blade damage. Verify all blade installations are correct and perform Replace Blades again if necessary.</p>

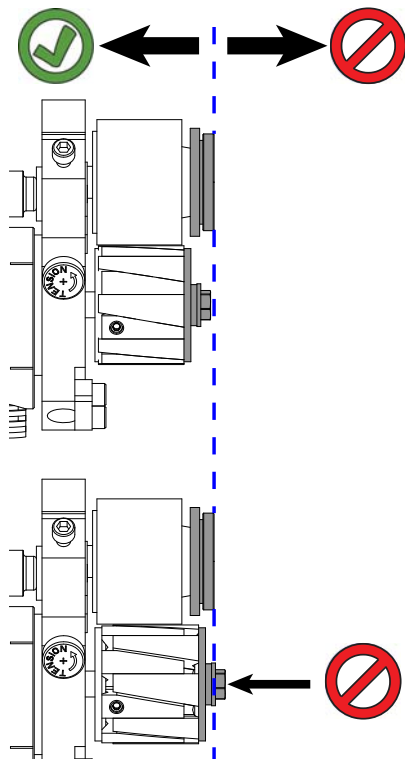

FIG. 7

Replace Chopper Chute Liner



- Follow the **Pressure Relief Procedure** in the RS Gun and Cutter, Operation-Repair manual. See **Related Manuals** on page 3.
- Engage the trigger lock on the gun.
- Remove the release knob (128) and cover (127).
- Remove the cutter cover plate (131).

<p>Blades are sharp. Always wear protective gloves to prevent cuts when the cutter cover is removed.</p>			

- Replace the chute liner (152). See **Cutter Chute Liner, 16P833** on page 31.
- Reattach the cutter cover plate (131), cover (127), and release knob (128).

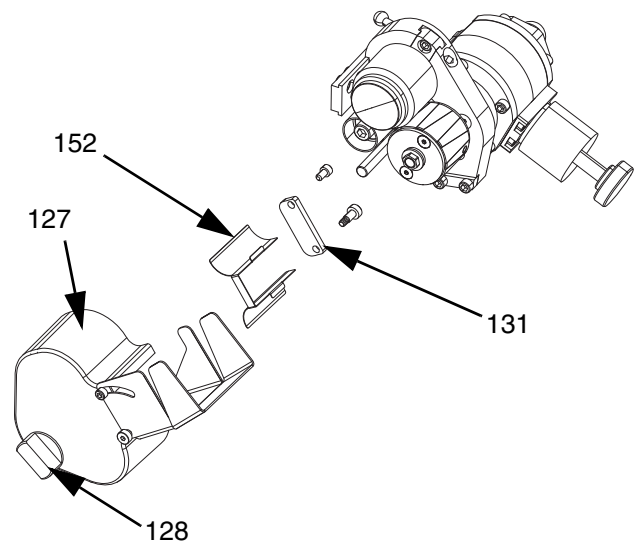

FIG. 8

Replace the Muffler Filters



1. Follow the **Pressure Relief Procedure** in the RS Gun and Cutter, Operation-Repair manual. See **Related Manuals** on page 3.
2. Engage the trigger lock on the RS gun.
3. Refer to **Figure 9**. Remove the muffler cap and speed control knob by turning the cap counterclockwise.
4. Discard the old muffler filter and replace it. See **Muffler Packing Kit, 25E494** on page 30.

NOTICE

Running the chopper without mufflers will result in air motor damage and reduced life of anvil and blades.

5. Install the muffler cap and speed control knob and tighten it until secure.

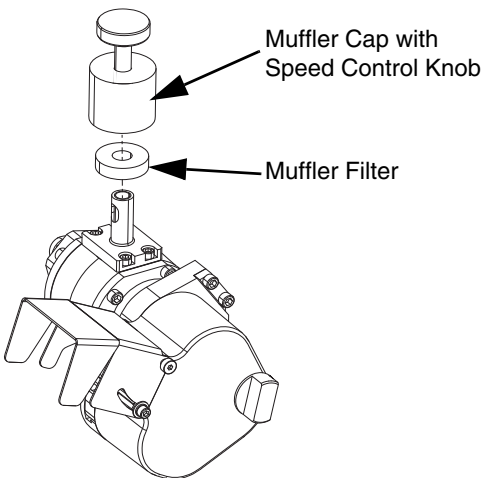

FIG. 9

NOTE: Failure to replace old mufflers will result in lower glass output. Running the chopper without mufflers will void the warranty of the chopper and air motor assemblies.

Troubleshooting



1. Follow the **Pressure Relief Procedure** in the RS Gun and Cutter, Operation-Repair manual before checking or repairing the cutter assembly or gun. See **Related Manuals** on page 3.
2. Check all possible problems and causes before disassembling the cutter assembly or gun.

Problem	Cause	Solution
Premature anvil or blade wear	Excessive tension between anvil and cutter head	Adjust Anvil to Cutter Head Tension , page 13.
	Cutter speed faster than necessary	Premature Blade or Anvil Wear , page 12.
Roving binds up in Cutter	Obstruction in roving path	Ensure the roving path is free from obstruction
	Overspray/binder build up on internal components	Clean components and reinstall the cover
	Resin on roving	Clean as necessary, keep roving away from resin and overspray.
	Incorrect anvil to idler wheel tension	Adjust Anvil to Idler Tension , page 14.
	Incorrect anvil to cutter blade assembly tension	Adjust Anvil to Cutter Head Tension , page 13.
	Cutter blade assembly is worn out	Replace.
	Anvil is worn out	Replace.
Cutter does not actuate when the gun is triggered	Air supply to gun is shut off	Open air supply.
	Speed control in off position	Adjust Cutter Speed , page 13.
	Quick release plunger stuck in	Inspect, clean and lubricate, replace if necessary.
	Incorrect anvil to idler wheel tension	Adjust Anvil to Idler Tension , page 14.
	Incorrect anvil to cutter blade assembly tension	Adjust Anvil to Cutter Head Tension , page 13.
	Cutter air valve stuck	Inspect and replace if necessary.
	Air motor is "locked up"	Add oil to air motor, Air Motor Oiling , page 15. Check for free rotation, replace if necessary.
Cutter is cutting long strands	Anvil to cutter blade tension is incorrect	Adjust Anvil to Cutter Head Tension , page 13.
	Anvil to blade tension lockdown is loose	Tighten the anvil to blade tension lockdown.
	Anvil is worn out	Replace Anvil , page 16.
	Cutter blade assembly is worn out	Replace Blades , page 16.
Air motor spins but doesn't cut glass	Cutter head set screws (606) loose.	Apply medium strength thread sealant and tighten.
	Anvil to cutter blade tension is incorrect	Adjust Anvil to Cutter Head Tension , page 13.

Problem	Cause	Solution
Air motor speed incorrect	Incoming air supply issues	Ensure proper air supply to gun, see Technical Specifications , page 33.
	Supply air volume too low	Ensure adequate air volume, see Technical Specifications , page 33.
	Air motor speed control set incorrectly	Adjust Cutter Speed , page 13.
	Anvil to cutter blade tension is too high	Adjust Anvil to Cutter Head Tension , page 13.
	Cutter blade assembly is worn out	Replace Blades , page 16.
	Air motor exhaust filter plugged	Clean and replace as necessary.

Repair



Numbers in parenthesis are used in this section for reference to callouts in **Parts** starting on page 26 and **Kits and Accessories** on page 30.

Air Motor Removal

Refer to **Figure 10** for the following steps.

1. Follow the **Pressure Relief Procedure** in the RS Gun and Cutter, Operation-Repair manual. See **Related Manuals** on page 3.
2. Disconnect the air tube (160) from the cutter assembly.
3. Loosen the set screws (106) and pull gently to remove the cutter head assembly.



4. Remove the four screws (104) that secure the air motor (102) to the plate (101). See **Figure 10**.
5. Separate the air motor (102) from the plate (101).

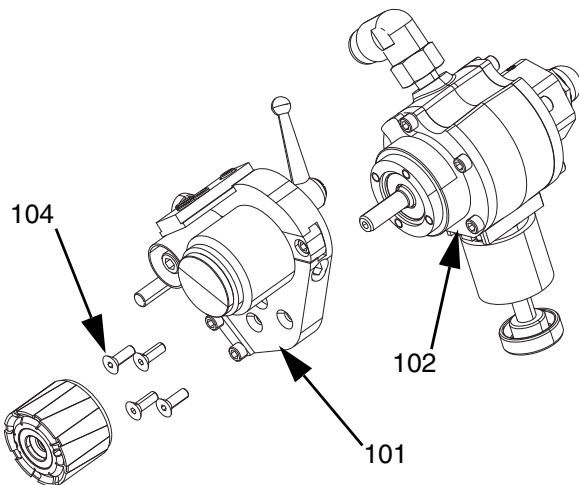

FIG. 10

Air Motor Disassembly

NOTE: The disassembly process requires kit 25E508.

Use the following steps to disassemble the air motor.

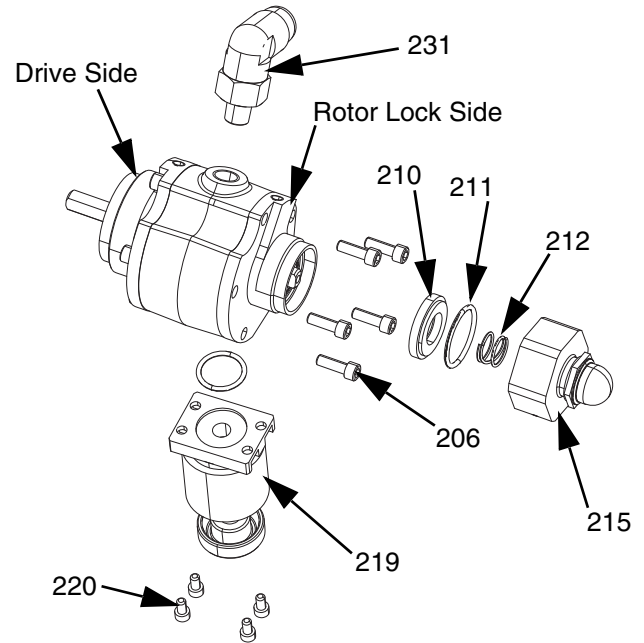

FIG. 11

1. To allow for ease of repair, remove the elbow fitting (231) using a crescent wrench.
2. To remove the muffler speed control (219) and packing o-ring (218), unscrew the muffler cap and speed control knob (see **See Replace the Muffler Filters** on page 18). Then remove the four cap screws (220) with a 7/64 in. hex wrench.
3. Loosen the two set screws (216) in the plunger stop retainer (215) using a 5/64 in. hex wrench, then use a crescent wrench to remove the plunger stop retainer (215). The plunger stop (214), packing o-ring (213), and rotor stop button (217) should remain intact with the plunger stop retainer (215).
4. Remove the spacer (210), o-ring (211), and compression spring (212). These three parts are loose and may fall out once the plunger stop retainer (215) is removed, depending on the orientation of the air motor during disassembly.

- Use a 9/64 in. hex wrench to remove the five screws (206) on the rotor lock side of the motor where you removed the other parts.

NOTICE

Do not remove or loosen the screws from the drive side of the air motor. Removing or loosening those screws damages the air motor and voids the motor's warranty.

- Thread the bearing puller tool (802) from kit 25E508 onto the thread of the plunger stop retainer (215) and hand tighten it.
- Thread the bolt (803) from kit 25E508 into the bearing puller and hand tighten it clockwise. Place a wrench on the hex head of the bolt and turn the bolt clockwise. The bolt pushes against the rotor shaft and allows you to remove the end cap (208).

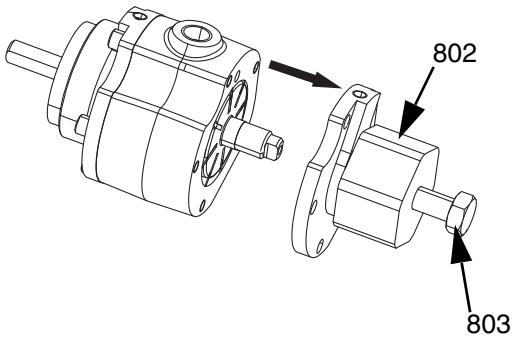

FIG. 12

- Place the air motor in an arbor press with the drive side of the motor shaft facing upward vertically. Use the arbor press to push down on the rotor shaft to remove the rotor (204).

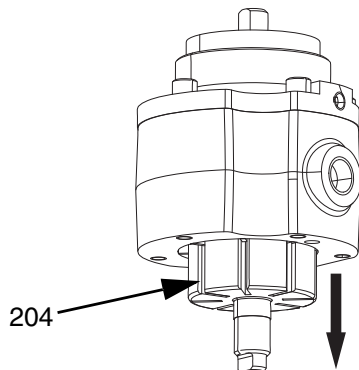

FIG. 13

NOTE: The eight motor vanes (207) should fall out of the rotor when the air motor is oriented this way. They can be discarded as they will be replaced with the motor vanes from rebuild kit 25E490.

- After removing the bearing puller tool, place the end cap (208) that was removed in steps 6-8 into the arbor press. Use the bearing removal tool (801) from kit 25E508 to remove the bearing (203) from the end cap (208).

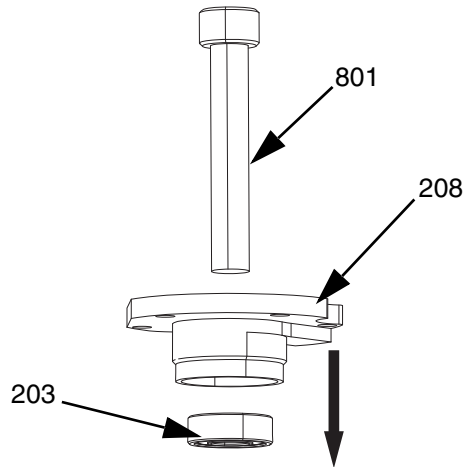

FIG. 14

- Place the drive side end cap (201) attached to the housing (205) into the arbor press. Use the bearing removal tool (801) to remove the bearing (203) and the shaft seal (209) from the end cap.

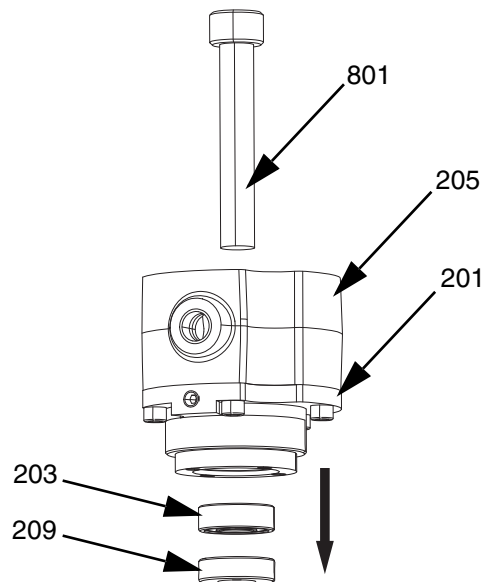

FIG. 15

Air Motor Rebuild

NOTE: The repair process requires kits 25E508 and 25E490.

1. Thoroughly clean the end caps (201, 208), housing (205), and rotor (204). Remove any accumulated oil or dust from the parts.
2. Place the rotor (204) inside the housing (205). Ensure that the shaft end of the rotor is protruding through the drive side end cap.

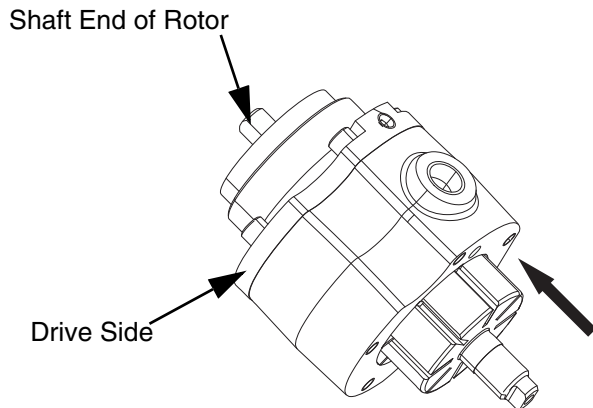

FIG. 16

3. Place the air motor in an arbor press with the drive side of the motor shaft facing upward vertically. Use one of the installation tools (805) included in kit 25E508 to press the new bearing (302) from kit 25E490 into the end cap (201) and onto the rotor shaft (204).

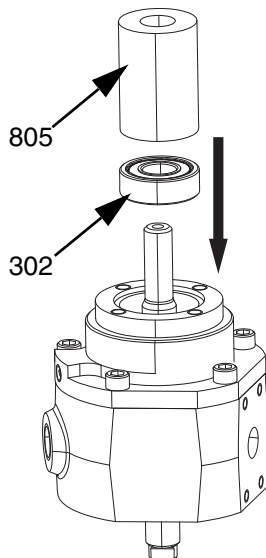

FIG. 17

4. Turn the motor so the rotor lock side is facing up. Install the eight motor vanes (301) from kit 25E490 into the rotor with the notched corners of the vanes facing the center of the rotor.

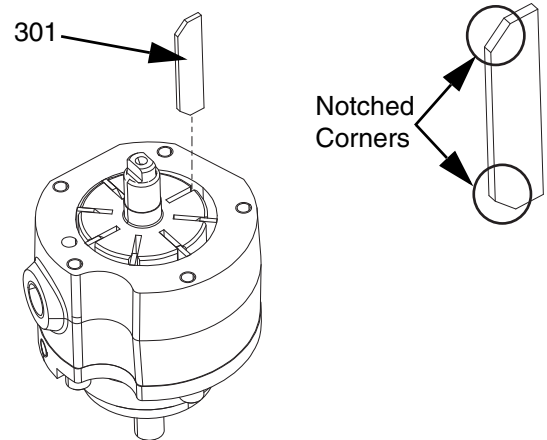

FIG. 18

NOTICE

Vanes installed with notches facing the motor housing can cause inoperable motors or motors with reduced performance.

5. Place the end cap (208) that was removed during disassembly onto the rotor lock side of the air motor housing.
6. Refer to **Figure 19** on page 24, Place one of the two installation tools (805) included in kit 25E508 over the rotor shaft (204) on the drive side of the air motor to protect the shaft.

- Place the air motor in an arbor press with the rotor lock side of the motor shaft facing upward vertically and use the other installation tool to press the new bearing (302) into the end cap (208).

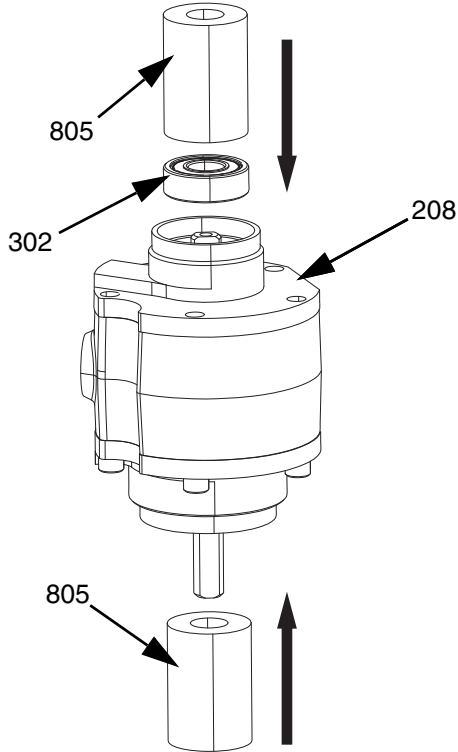

FIG. 19

- Install the five screws through the end cap and torque the screws to 22-27 in-lbs (2.5-3.1 N•m) using a star pattern when tightening.

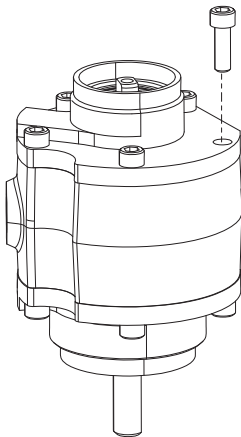

FIG. 20

NOTE: At this point in the rebuild process, it is important to ensure that the rotor turns freely and is not rubbing against the end caps. You can check this by turning the drive shaft while pushing and pulling the shaft. If you can feel the rotor making contact with an end cap when you are turning the drive shaft, refer to **Figure 21** and follow steps 9-11.

- Pull the drive shaft while turning it. If you feel the rotor scraping, use the bearing adjustment tool (804) included in Rebuild Kit 25E508 to tap lightly on the bearing inner race on the rotor lock side of the motor to draw the rotor towards the rotor lock side and away from the drive side end cap.
- Push the drive shaft while turning it. If you feel it scraping, use the bearing adjustment tool to tap lightly on the bearing inner race on the drive side of the motor to draw the rotor towards the drive side and away from the rotor lock side end cap.

NOTE: The bearing adjustment tool is designed to only make contact with the inner race of the bearing to adjust the rotor.

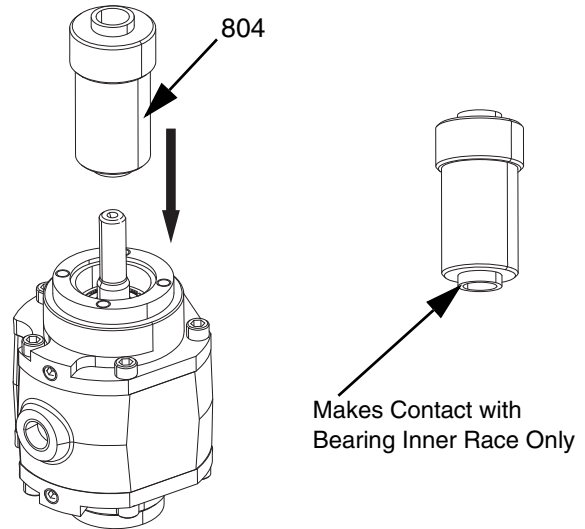

FIG. 21

- If necessary, repeat rotating the drive shaft while pulling and pushing it and use the bearing adjustment tool until the rotor is centered in the housing and not contacting either end cap.

- Apply a general-purpose, high temperature grease to the inside of the cap seal (303). Place the air motor in an arbor press with the drive side of the motor shaft facing upward vertically and use the installation tool (805) to press the seal (303) into the end cap (201) and onto the rotor shaft (204).

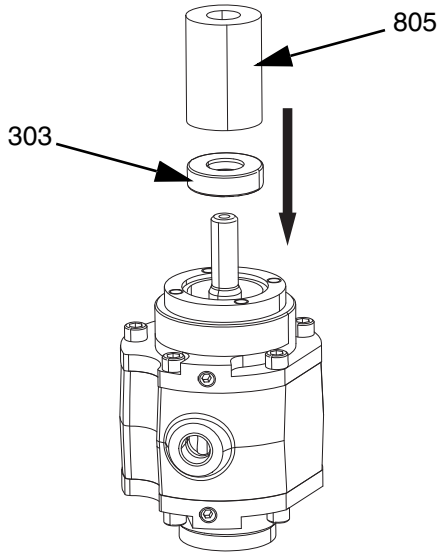

FIG. 22

- Holding the air motor in a vertical position with the rotor lock side facing up, replace the spacer (210), o-ring (211), and compression spring (212).
- Replace the plunger stop retainer (215), which includes the packing o-ring (213), plunger stop (214), and rotor stop button (217). Tighten the plunger stop retainer using a crescent wrench.
- Tighten the two set screws (216) using a 5/64 in. hex wrench.
- Attach the elbow fitting (231) using a crescent wrench.
- To reattach the muffler speed control (219), replace the packing o-ring (218) and attach the muffler speed control base using the four cap screws that were removed during disassembly and a 7/64 in. hex wrench. Then screw on the speed control cap until tight.

Air Motor Replacement

Refer to **Figure 23** for the following steps.

- Verify the two o-rings (103,157) are installed between the back plate (101) and the air motor (102).

NOTICE

The air motor will not function properly if it is installed incorrectly. Ensure the air motor is installed as described.

- With the air motor and back plate oriented as shown below, use four screws (104) to fasten them together.

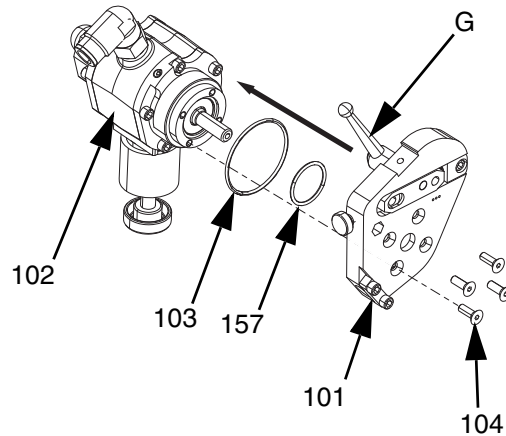

FIG. 23

NOTE: The anvil to blade tension lockdown handle (G) must be aligned with the groove in the air motor as shown in **Figure 23**.

Parts

Cutter Assembly, 24E512 and 24P681

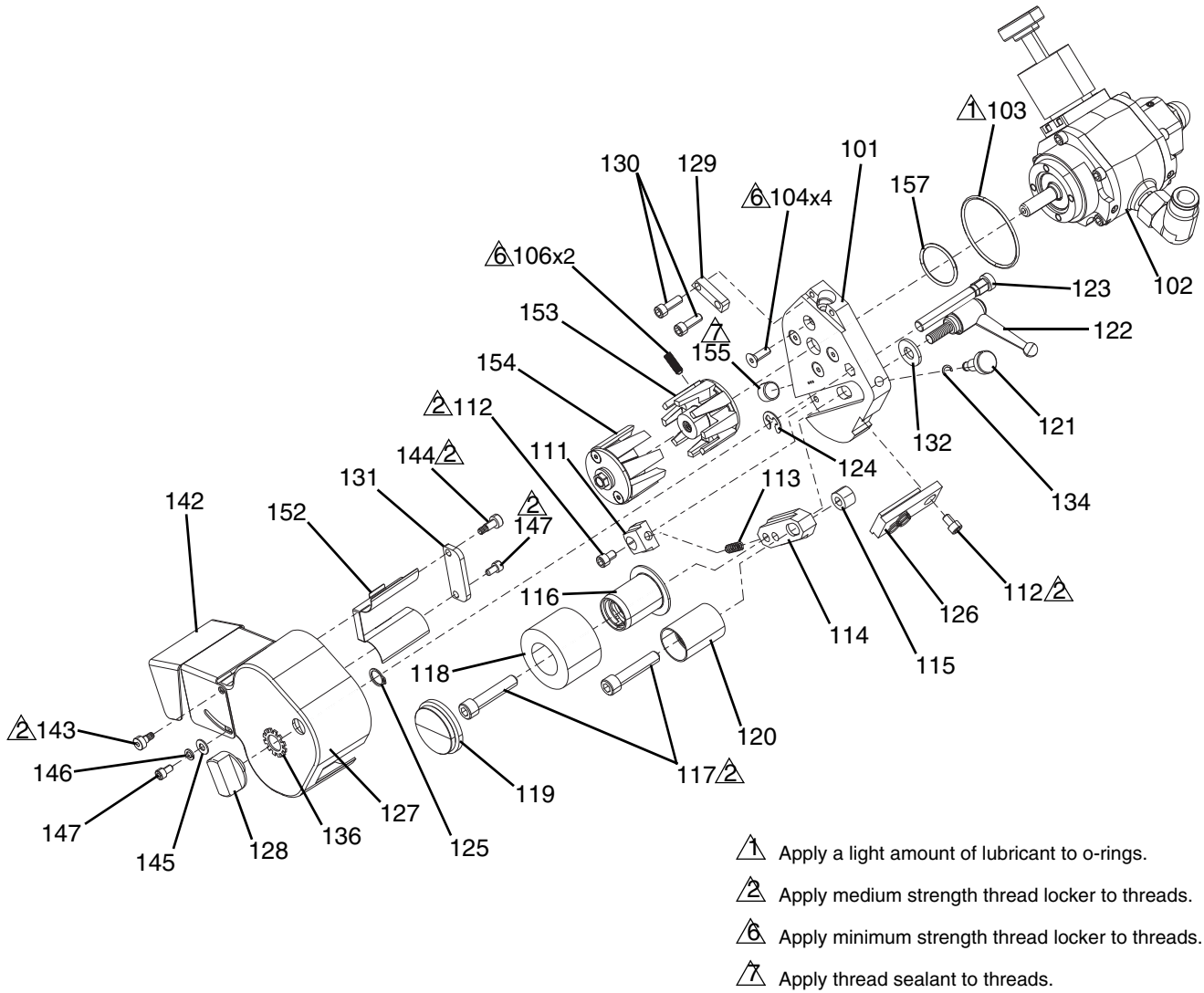

FIG. 24: Cutter Assembly Parts

Cutter Assembly Parts List

Ref	Description	Qty	Ref	Description	Qty
101	16C677 PLATE, cutter back	1	145	154570◆‡ WASHER, flat	1
102	24E511 MOTOR, air	1	146	100068◆‡ WASHER, lock, spring	1
103	117519 O-RING	1	147	124781◆‡ SCREW, cap, socket head, 6-32x.25lg, SST	2
104	111945 SCREW, cap, flat head	4	152	16P833◆‡ LINER, RS gun chopper	1
106	124612 SCREW, set, #8-32x1/2 long, SST	2	153	24R480❖ HEAD, base, cutter assembly	1
111	16C686 PLATE, spring retainer	1	154	24R481❖ HEAD, clamp, cutter assembly	1
112	123909 SCREW, cap, socket head, 8-32x.250lg, sst	2	155	110208 PLUG, pipe, headless	1
113	123882 SPRING, slide, anvil	1	157	111603 PACKING, o-ring, ptfe	1
114	16C678 PLATE, slider mounting	1	158	125383 FITTING, elbow, 1/8 npt, 3/8 tube, brass	1
115	16C679 NUT, idler mounting	1	159	295662 PLUG, pipe	1
116	258902* SLEEVE, anvil, assembly	1	160	061374 TUBE, poly, 3/8 in. black	0.7 ft
117	124588*★ SCREW, cap, socket head, 1/4-20x1.25lg, SST	2		* <i>Parts included in anvil sleeve kit 24S001.</i>	
118	126995 WHEEL, anvil, cutter	1		★ <i>Parts included in idler assembly kit 24H273.</i>	
119	24R341* CAP, anvil sleeve	1		◆ <i>Parts included in cutter cover kit 24H282.</i>	
120	258901★ BEARING, idler assembly	1		‡ <i>Parts included in cutter cover kit 24P683.</i>	
121	16C687 SCREW, spring tension	1		❖ <i>Parts included in cutter head kit 24R482.</i>	
122	124048 HANDLE, clamp, cutter	1			
123	16C691 TUBE, blower	1			
124	123883 RING, retaining, e-ring	1			
125	124316◆‡ RING, snap	1			
	24F038 BAR, feed, cutter	1			
126	24M569 OPTIONAL - BAR, feed, cutter, 2 hole	1			
127	24N712◆‡ COVER, cutter, machined	1			
128	16C697◆‡ KNOB, cover release	1			
129	16C676 CLAMP, air pivot	1			
130	124057 SCREW, cap, socket head, 8-32x0.5lg, SST	2			
131	16D534◆‡ PLATE, cutter cover	1			
132	110755 WASHER, plain	1			
134	24E432 RING, retaining, e-ring (pack of 6)	1			
136	100639◆‡ WASHER, lock	1			
	16K759◆ DEFLECTOR, chute, open, RS, external mix	1			
142	16K762‡ DEFLECTOR, chute, open, RS, internal mix	1			
143	124345◆‡ SCREW, shoulder, 6-32x0.125 long	1			
144	124346◆‡ SCREW, shoulder 6-32x0.25 long	1			

Air Motor, 24E511

NOTICE

The air motor cannot be serviced at any lower level than what is pictured here. If the air motor issue cannot be corrected at this level, it must be replaced.

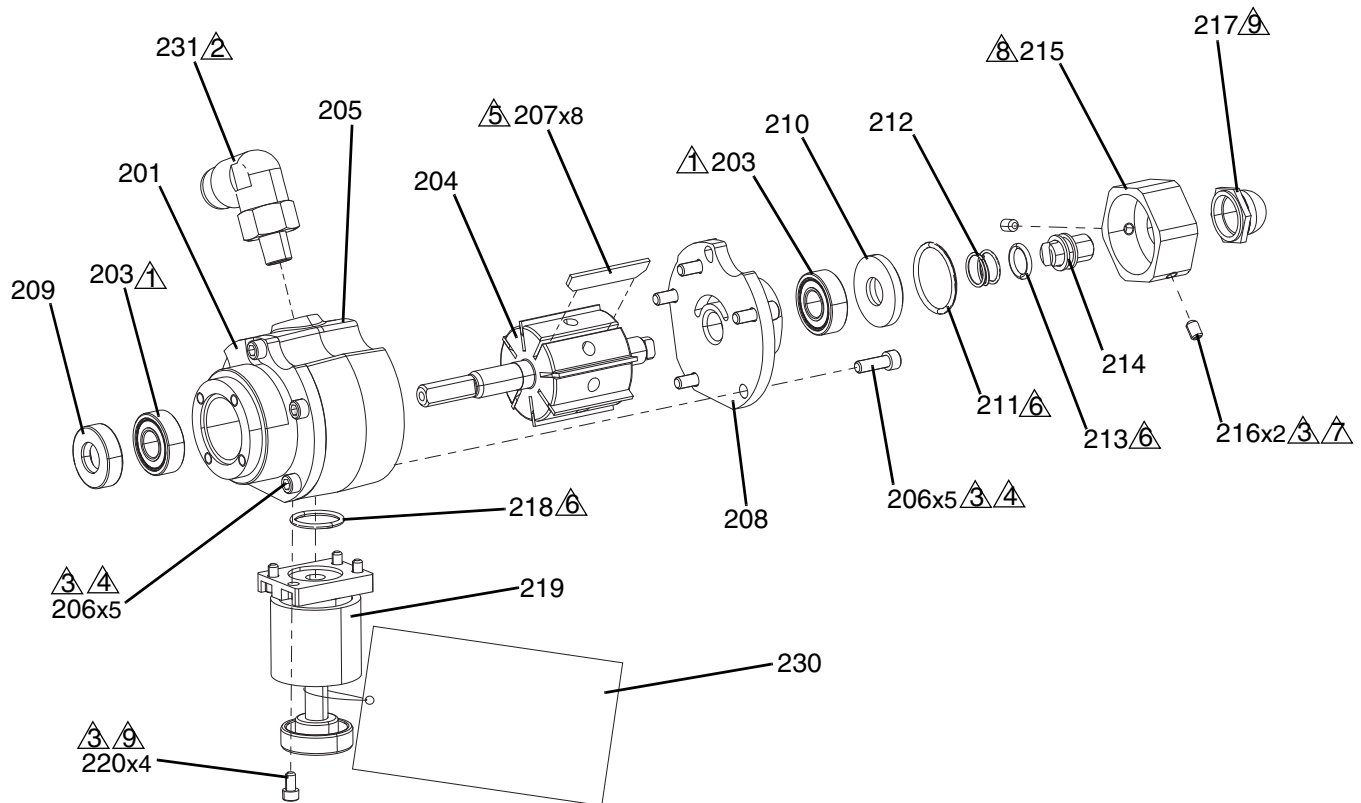

- 1 Apply a thin layer of oil to bearing and rotor shaft before pressing together.
- 2 Apply sealant to threads.
- 3 Apply blue sealant to threads before assembling.
- 4 Torque to 22-27 in-lbs (2.5-3.1 N•m).
- 5 Apply a thin layer of oil to vanes.
- 6 Apply a thin layer of grease to all o-rings before assembling.
- 7 Torque to 16-19 in-lbs. (1.8-2.1 N•m).
- 8 Torque to 96-120 in-lbs. (10.8-13.6 N•m).
- 9 Torque to 15-20 in-lbs. (1.7-2.3 N•m).

FIG. 25: Air Motor Parts

Air Motor Parts List

Ref	Part	Description	Quantity
201	---	CAP, motor, air, drive, plugged	1
203	---*	BEARING, ball	2
204	---	ROTOR, motor, air	1
205	---	HOUSING, motor, air, machined	1
206	124057	SCREW, cap, sh, 8-32 x 0.5 lg, sst	10
207	---*	VANE, motor	8
208	---	CAP, motor, air, end, plugged	1
209	---*	SEAL, shaft, radial	1
210	---	SPACER, spring	1
211	117559★	O-RING	1
212	17E783★	SPRING, compression	1
213	111316★	PACKING, o-ring	1
214	---	PLUNGER, stop	1
215	---	RETAINER, plunger, stop	1
216	112385	SCREW, set, socket hd	2
217	---★‡	COVER, button, stop	1
218	116768◆	PACKING, o-ring	1
219	---◆	MUFFLER, control, speed, motor, air	1
220	124781◆	SCREW, cap, sh, 6-32 x .25 lg, sst	4
230	129118▲	LABEL, safety, notice	1
231	125383	FITTING, elbow, 1/8 npt, 3/8 tube, brass	2
235	295662	PLUG, pipe	1
236	061374	TUBE, poly, 3/8 in. black	0.7 ft

--- Not available for individual sale.

▲ Replacement safety labels, tags, and cards are available at no cost.

* Parts included in air motor rebuild kit 25E490.

★ Parts included in anti-rotation rebuild kit 25E491.

◆ Parts included in muffler kit 25E492.

‡ Part included in stop button cover kit 25E493.

NOTE: Refer to **Kits and Accessories** on page 30.

Kits and Accessories

Air Motor Rebuild Kit, 25E490

Ref	Part	Description	Qty
301	---	VANE, motor	8
302	---	BEARING	2
303	---	SEAL, shaft, radial	1

Anti-Rotation Rebuild Kit, 25E491

Ref	Part	Description	Qty
401	117559	O-RING	1
402	---	SPRING, compression	1
403	111316	PACKING, o-ring	1
404	---	COVER, button, stop	1

Muffler Kit, 25E492

Ref	Part	Description	Qty
501	---	MUFFLER, control, speed, motor air	1
502	124781	SCREW, cap, sh, 6032, 25 lg, sst	4
503	116768	PACKING, o-ring	1

Stop Button Cover Kit, 25E493

Ref	Part	Description	Qty
601	---	COVER, button, stop	5

Muffler Packing Kit, 25E494

Ref	Part	Description	Qty
701	21562-00	WASHER, felt, muffler, chopper	5

Air Motor Rebuild Tools Kit, 25E508

Ref	Part	Description	Qty
801	---	TOOL, bearing, removal	1
802	---	TOOL, bearing, puller	1
803	124227	BOLT	1
804	---	TOOL, bearing, inner race	1
805	---	TOOL, bearing, install	2

--- Not available for individual sale.

Chopper Air Shutoff, 24F706

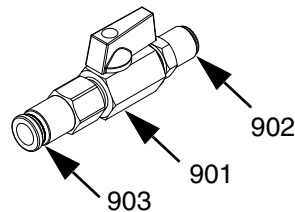

Ref	Part	Description	Qty
901	15B565	VALVE, ball	1
902	123737	FITTING, tube, push connector	1
903	16F710	CONNECTOR, 3/8 tube	1

External Mix Gel Gun to Chop Gun Conversion

To convert your external mix gel gun to a chop gun, purchase and install the following kits:

- External Mix Cutter Adapter Kit, 24E422
- Trigger Air Valve Kit, 24E425
- Cutter Assembly, 24E512

To complete the conversion from an external mix gel gun to a chop gun, remove catalyst the restrictor from the gun. Refer to the RS Gun and Cutter Operation-Repair manual. See **Related Manuals** on page 3.

Internal Mix Gel Gun to Chop Gun Conversion

To convert your internal mix gel gun to a chop gun, purchase and install the following kits:

- Internal Mix Cutter Adapter Kit, 24G832
- Trigger Air Valve Kit, 24E425
- Cutter Assembly, 24E512
- Blank Housing Assembly, 24M045

To complete the conversion from an internal mix gel gun to a chop gun, replace housing from gun. Refer to the RS Gun and Cutter Operation-Repair manual. See **Related Manuals** on page 3.

Oil for Air Motor

202659, 16 oz.

SDS sheets are available at www.graco.com.

Cutter Chop Chutes

Additional chopper chutes for adapting to different glass pattern needs.

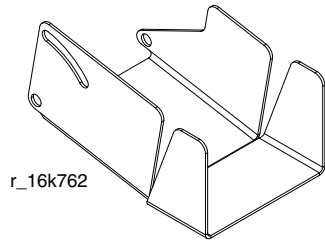

r_16k762

16K762 Shown

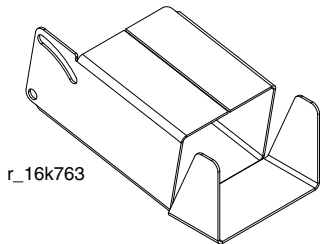

r_16k763

16K763 Shown

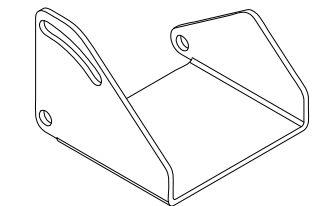

ti21023a

16K759 Shown

Part	Description	Qty
16K759	CHUTE, open, external mix, adjustable, 1.77x2.4 in. (45x61 mm)	1
16K760	CHUTE, closed, external mix, adjustable, 1.77x2.4 in. (45x61 mm)	1
16K762	CHUTE, open, internal mix, adjustable, 1.77x3.0 in. (45x76 mm)	1
16K763	CHUTE, closed, internal mix, adjustable, 1.77x3.0 in. (45x76 mm)	1
125883	CHUTE, closed, internal mix, 1 in. (25.4 mm) square exit	1
125884	CHUTE, closed, internal mix, 1.75x0.75 in. (44x19 mm) rectangular exit	1

Cover and Chutes

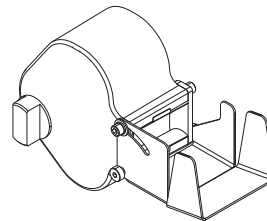

ti21024a

24H282 Shown

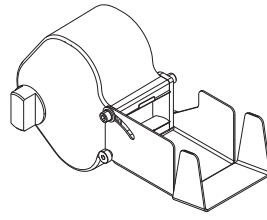

ti21025a

24P683 Shown

Part	Description	Qty
24H282	KIT, cutter cover, external mix	1
24P683	KIT, cutter cover, internal mix	1
19A648	CHUTE, external mix, sst	1

Blade Cartridges

Pack of 5 cartridges

- 4 blade cartridge - 24E448
- 6 blade cartridge - 24F602
- 8 blade cartridge - 24E449

Cutter Chute Liner, 16P833

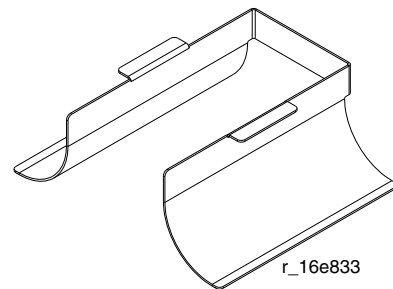

r_16e833

Tools

Hex Keys for Guns, 24F007

Includes:

- One 3/32 in. hex key
- One 9/64 in. hex key

Hex Keys for Cutter, 24F008

Includes:

- One 3/32 in. hex key
- One 9/64 in. hex key
- One 3/16 in. hex key

Carbide Resin Seat, 24M833

Ideal for use with heavily filled materials. It is to replace standard resin seat 16C104.

Two Hole Feeder Bar, 24M569

Ideal for use with only two strands of roving. It is to replace standard feeder bar 24F038.

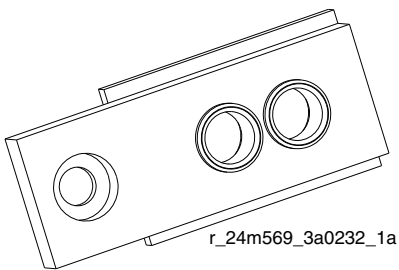

Cutter Head Kits

Cutter Base Assembly, 24R480

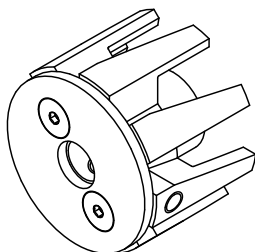

Clamp Cutter Assembly, 24R481

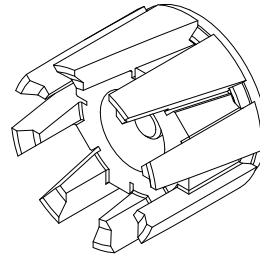

Cutter Head Assembly, 24R482

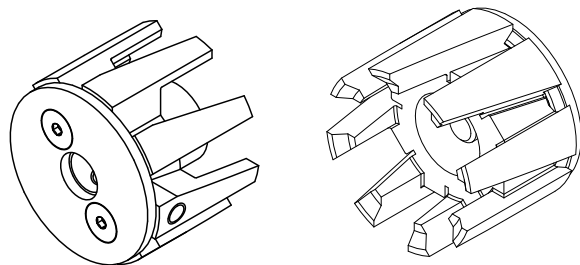

Cutter Head Assembly, 24H271

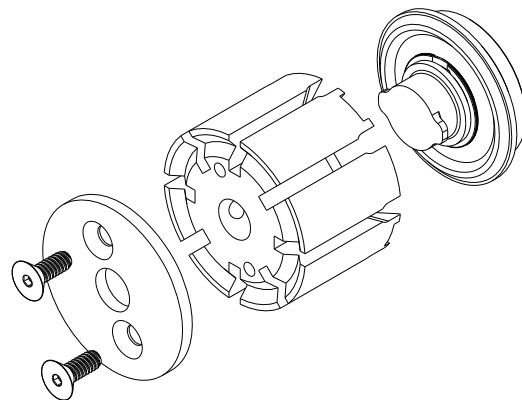

Blades, 24R606

Pack of 100 blades.

High Wear Wheel

420018 WHEEL, Anvil, Cutter (Optional replacement for 126995 only)

Technical Specifications

RS Cutter Assemblies		
	US	Metric
Air Inlet Working Pressure		
24E512	80-100 psi	5.5-7.0 bar, 0.55-0.7 MPa
24P681		
Cutter Glass Output - using recommended test set up of: 90 psi (6.2 bar, 0.62 MPa) static air pressure at the machine and 25 ft hose bundle		
One Strand	4.1 lb/min	1.9 kg/min
Two Strands	7.1 lb/min	3.2 kg/min
Three Strands	9.3 lb/min	4.2 kg/min
Weight		
24E512	2.69 lb	1.22 kg
24P681		
Sound Power Measured per ISO-3744		
24E512	95.9 dB(A) at 100 psig and maximum speed	
24P681		
Sound Pressure Measured at 3 ft (1 m) from equipment.		
24E512	84.3 dB(A) at 100 psig and maximum speed	
24P681		
Maximum Air Pressure	100 psi	7.0 bar, 0.7 MPa
Materials of Construction	Aluminum, stainless steel, carbon steel, carbide, chemically resistant o-rings	

Graco Standard Warranty

Graco warrants all equipment referenced in this document which is manufactured by Graco and bearing its name to be free from defects in material and workmanship on the date of sale to the original purchaser for use. With the exception of any special, extended, or limited warranty published by Graco, Graco will, for a period of twelve months from the date of sale, repair or replace any part of the equipment determined by Graco to be defective. This warranty applies only when the equipment is installed, operated and maintained in accordance with Graco's written recommendations.

This warranty does not cover, and Graco shall not be liable for general wear and tear, or any malfunction, damage or wear caused by faulty installation, misapplication, abrasion, corrosion, inadequate or improper maintenance, negligence, accident, tampering, or substitution of non-Graco component parts. Nor shall Graco be liable for malfunction, damage or wear caused by the incompatibility of Graco equipment with structures, accessories, equipment or materials not supplied by Graco, or the improper design, manufacture, installation, operation or maintenance of structures, accessories, equipment or materials not supplied by Graco.

This warranty is conditioned upon the prepaid return of the equipment claimed to be defective to an authorized Graco distributor for verification of the claimed defect. If the claimed defect is verified, Graco will repair or replace free of charge any defective parts. The equipment will be returned to the original purchaser transportation prepaid. If inspection of the equipment does not disclose any defect in material or workmanship, repairs will be made at a reasonable charge, which charges may include the costs of parts, labor, and transportation.

THIS WARRANTY IS EXCLUSIVE, AND IS IN LIEU OF ANY OTHER WARRANTIES, EXPRESS OR IMPLIED, INCLUDING BUT NOT LIMITED TO WARRANTY OF MERCHANTABILITY OR WARRANTY OF FITNESS FOR A PARTICULAR PURPOSE.

Graco's sole obligation and buyer's sole remedy for any breach of warranty shall be as set forth above. The buyer agrees that no other remedy (including, but not limited to, incidental or consequential damages for lost profits, lost sales, injury to person or property, or any other incidental or consequential loss) shall be available. Any action for breach of warranty must be brought within two (2) years of the date of sale.

GRACO MAKES NO WARRANTY, AND DISCLAIMS ALL IMPLIED WARRANTIES OF MERCHANTABILITY AND FITNESS FOR A PARTICULAR PURPOSE, IN CONNECTION WITH ACCESSORIES, EQUIPMENT, MATERIALS OR COMPONENTS SOLD BUT NOT MANUFACTURED BY GRACO. These items sold, but not manufactured by Graco (such as electric motors, switches, hose, etc.), are subject to the warranty, if any, of their manufacturer. Graco will provide purchaser with reasonable assistance in making any claim for breach of these warranties.

In no event will Graco be liable for indirect, incidental, special or consequential damages resulting from Graco supplying equipment hereunder, or the furnishing, performance, or use of any products or other goods sold hereto, whether due to a breach of contract, breach of warranty, the negligence of Graco, or otherwise.

FOR GRACO CANADA CUSTOMERS

The Parties acknowledge that they have required that the present document, as well as all documents, notices and legal proceedings entered into, given or instituted pursuant hereto or relating directly or indirectly hereto, be drawn up in English. Les parties reconnaissent avoir convenu que la rédaction du présente document sera en Anglais, ainsi que tous documents, avis et procédures judiciaires exécutés, donnés ou intentés, à la suite de ou en rapport, directement ou indirectement, avec les procédures concernées.

Graco Information

Sealant and Adhesive Dispensing Equipment

For the latest information about Graco products, visit www.graco.com.

For patent information, see www.graco.com/patents.

TO PLACE AN ORDER, contact your Graco distributor, go to www.graco.com, or call to identify the nearest distributor.

If calling from the USA: 1-800-746-1334

If calling from outside the USA: 0-1-330-966-3000

All written and visual data contained in this document reflects the latest product information available at the time of publication. Graco reserves the right to make changes at any time without notice.

Original instructions. This manual contains English. MM 332574

Graco Headquarters: Minneapolis

International Offices: Belgium, China, Japan, Korea

GRACO INC. AND SUBSIDIARIES • P.O. BOX 1441 • MINNEAPOLIS MN 55440-1441 • USA
Copyright 2018, Graco Inc. All Graco manufacturing locations are registered to ISO 9001.

www.graco.com
Revision G, February 2019